

# *Shark* MATRIX™ PLUS

## Robot Vacuum

UR2360S  
OWNER'S GUIDE

---



# IMPORTANT SAFETY INSTRUCTIONS

PLEASE READ CAREFULLY BEFORE USE • FOR HOUSEHOLD USE ONLY

If the charging cable plug does not fit fully into the outlet, reverse the plug. If it still does not fit, contact a qualified electrician. DO NOT force into outlet or try to modify to fit.

## WARNING

To reduce the risk of fire, electric shock, injury, or property damage:

### LASER WARNING

**THIS PRODUCT HAS A CLASS 1 LASER. IT IS SAFE UNDER REASONABLY FORESEEABLE CONDITIONS (AS DEFINED IN THESE INSTRUCTIONS.) ALWAYS TURN OFF THE POWER BEFORE LIFTING THE ROBOTIC VACUUM CLEANER OR PERFORMING ANY MAINTENANCE ON IT. DO NOT LOOK DIRECTLY INTO LASER.**

### GENERAL WARNINGS

1. Remove cords from the area to be cleaned.
2. Do not operate the robotic vacuum cleaner in a room where an infant or child is sleeping.
3. Do not operate the robotic vacuum cleaner in an area where there are lit candles or fragile objects on the floor to be cleaned.
4. Do not operate the robotic vacuum cleaner in a room that has lit candles on furniture that the robotic vacuum cleaner may accidentally hit or bump into.
5. Do not allow children to sit on the robotic vacuum cleaner.
6. Do not use the robot on a wet surface, unless it is a WD model mopping robot.

**When using an electrical appliance, basic precautions should always be followed, including the following:**

7. The robotic vacuum cleaner system consists of a robotic vacuum and a Self-Empty Base with a power supply. These components contain electrical connections, electrical wiring, and moving parts that potentially present risk to the user.
8. Before each use, carefully inspect all parts for any damage. If a part is damaged, discontinue use.
9. Use only identical replacement parts.
10. This robotic vacuum cleaner contains no serviceable parts.
11. Use only as described in this Owner's Guide. **DO NOT** use the robotic vacuum cleaner for any purpose other than those described in this Owner's Guide.
12. With the exception of filters, **DO NOT** expose any parts of the robotic vacuum cleaner to water or other liquids.

13.  **DO NOT put hands into any opening in the Self-Empty Base or robot.**

### USE WARNINGS

14. For your robot's cliff sensors to work properly, all runners, rugs, or carpets must be eight inches from any stairs (or must be continuous and extend over the edge of the stairs). If a runner, rug, or carpet edge that is less than eight inches from the stairs cannot be moved, you must use a digital no-go zone to block off the stairs. For non-app users, use a boundary to block off an unsafe boundary.
15. To minimize the risk of the robotic vacuum cleaner traveling beyond an unsafe boundary (stair/cliff edges, fireplaces, water hazards), establish these areas as no-go zones using the mapping feature in the SharkClean® mobile app. Upon setting the boundary, run the vacuum and visually confirm that the settings effectively prevent it from passing beyond the set boundary. Adjust settings as necessary.
16. This product has a Class 1 Laser. It is safe under reasonably foreseeable conditions (as defined in this Owner's Guide). Always turn off the power before lifting the robotic vacuum cleaner or performing any maintenance on it.
17. **DO NOT** look directly into laser.
18. Always turn off the robotic vacuum cleaner before inserting or removing the filter or dust bin.
19. **DO NOT** handle plug, Self-Empty Base, charging cable, or robotic vacuum cleaner with wet hands. Cleaning and user maintenance shall not be made by children without supervision.
20. **DO NOT** use without robot dust bin and filters in place.
21. **DO NOT** damage the cord:
  - a) **DO NOT** pull or carry Self-Empty Base by the cord or use the cord as a handle.
  - b) **DO NOT** unplug by pulling on cord. Grasp the plug, not the cord.
  - c) **DO NOT** close a door on the cord, pull the cord around sharp corners, or leave the cord near heated surfaces.

- 22. DO NOT** put any objects into nozzle or accessory openings. **DO NOT** use with any opening blocked; keep free of dust, lint, hair, and anything that may reduce airflow.
- 23. DO NOT** use robotic vacuum cleaner if airflow is restricted. If the air paths become blocked, turn the vacuum cleaner off and remove all obstructions before turning on the unit again.
- 24.** Keep nozzle and all vacuum openings away from hair, face, fingers, uncovered feet, or loose clothing.
- 25. DO NOT** use if robotic vacuum cleaner is not working as it should, or has been dropped, damaged, left outdoors, or dropped into water.
- 26. DO NOT** place robotic vacuum cleaner on unstable surfaces.
- 27. DO NOT** use to pick up:
- Liquids.
  - Large objects.
  - Hard or sharp objects (glass, nails, screws, or coins).
  - Large quantities of dust (drywall dust, fireplace ash, or embers.)
  - DO NOT** use as an attachment to power tools for dust collection.
  - Smoking or burning objects (hot coals, cigarette butts, or matches).
  - Flammable or combustible materials (lighter fluid, gasoline, or kerosene).
  - Toxic materials (chlorine bleach, ammonia, or drain cleaner).
  - Toxic materials (high concentrations of chlorine bleach liquid, high concentrations of ammonia, or drain cleaning solution).
- 28. DO NOT** use in the following areas:
- Wet or damp surfaces.
  - Outdoor areas near fireplaces with unobstructed entrances.
  - Spaces that are enclosed and may contain explosive or toxic fumes or vapors (lighter fluid, gasoline, kerosene, paint, paint thinners, mothproofing substances, or flammable dust.)
  - In an area with a space heater.
  - Near fireplaces with unobstructed entrances.
- 29.** Turn off the robotic vacuum cleaner before any adjustment, cleaning, maintenance, or troubleshooting.
- 30.** Allow all filters to air-dry completely before reinstalling them to prevent liquid from being drawn into electric parts.
- 31. DO NOT** modify or attempt to repair the robotic vacuum cleaner or the battery yourself, except as indicated in this Owner's Guide. **DO NOT** use the vacuum if it has been modified or damaged.
- 32. DO NOT** use any household cleaners (all-purpose cleaners, glass cleaners, bleach) on any of the polished high gloss surfaces on the Self-Empty Base or robotic vacuum cleaner as they contain chemicals that may damage these surfaces. Instead, use a cloth dampened with water to gently clean.

#### **BATTERY USE**

- 33.** The battery is the power source for the robotic vacuum cleaner. Carefully read and follow all charging instructions.
- 34.** To prevent unintentional starting, ensure the robotic vacuum cleaner is powered off before picking it up or carrying it. **DO NOT** carry the appliance with your finger on the power switch.
- 35.** Use ONLY the Shark® charging dock XDKUR2360S for robot UR2360S. For replacement battery, use RVBAT850 (26V) or RVBAT85004 (EVE20P) or RVBAT85005 (SP20P) battery packs.
- 36.** Keep the battery away from all metal objects such as paper clips, coins, keys, nails, or screws. Shorting the battery terminals together increases the risk of fire or burns.
- 37.** Under abusive conditions, liquids may be ejected from the battery. Avoid contact with this liquid, as it may cause irritation or burns. If contact occurs, flush with water. If liquid contacts eyes, seek medical help.
- 38.** Robotic vacuum cleaner should not be stored, charged, or used at temperatures below 50°F (10°C) or above 104°F (40°C). Ensure the battery and vacuum have reached room temperature before charging or use. Exposing the robot or battery to temperatures outside of this range may damage the battery and increase the risk of fire.
- 39. DO NOT** expose the robotic vacuum cleaner or battery to fire or temperatures above 265°F (130°C) as it may cause explosion.

## **SAVE THESE INSTRUCTIONS**

For the latest warnings and cautions, go to [support.sharkclean.com](https://support.sharkclean.com)

# GETTING TO KNOW YOUR SHARK MATRIX™ PLUS

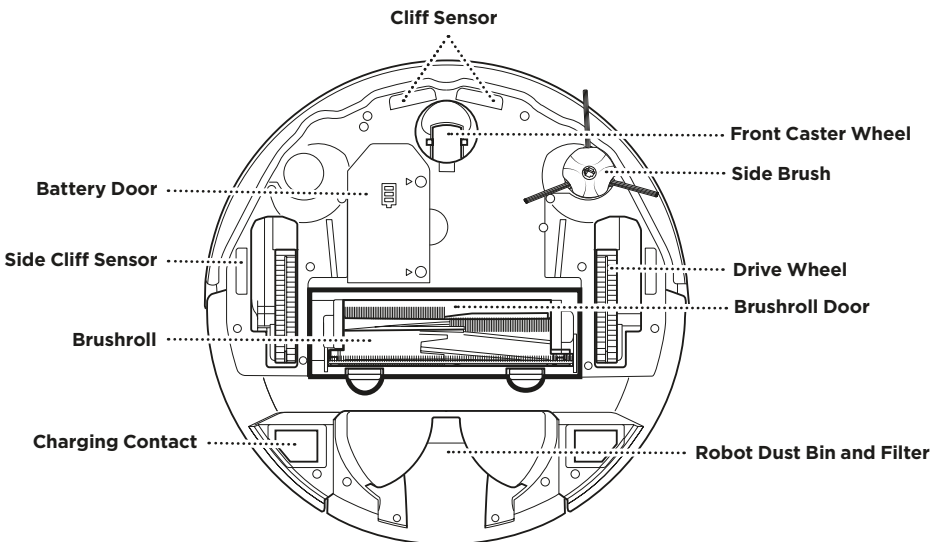
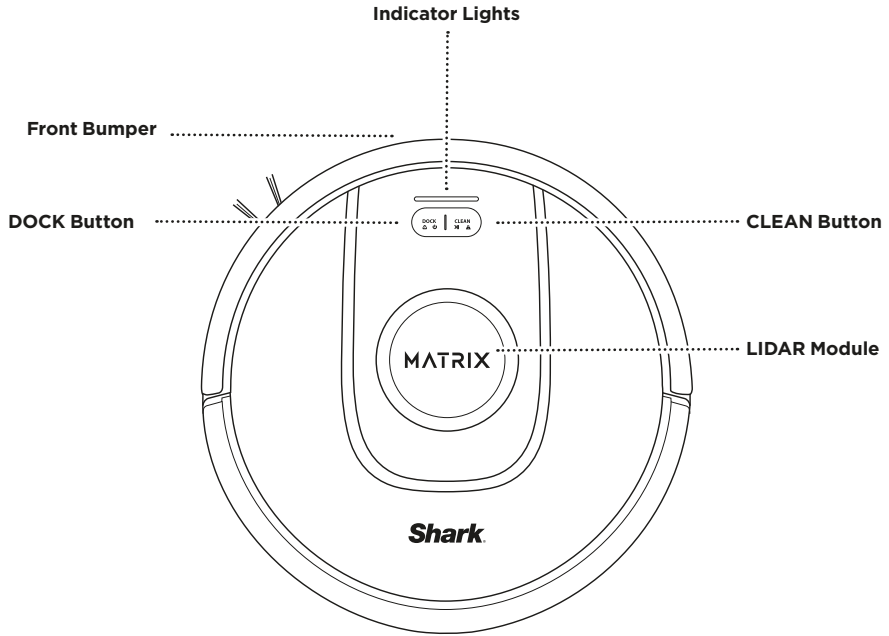

**SELF-EMPTY BASE  
FRONT**

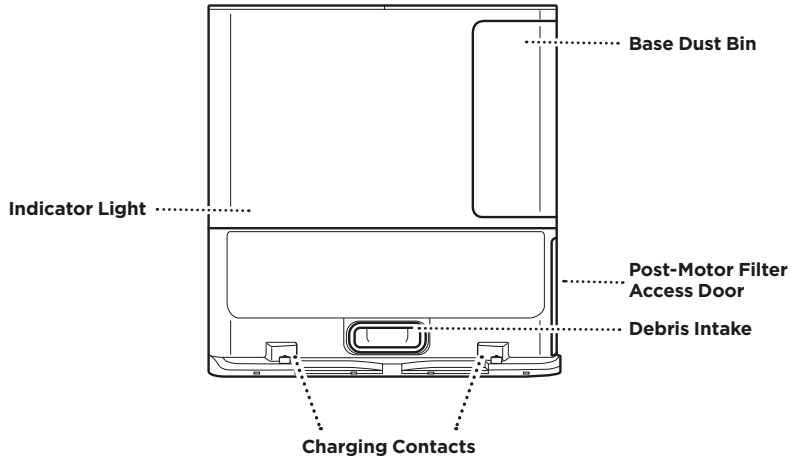

**SELF-EMPTY BASE  
BACK**

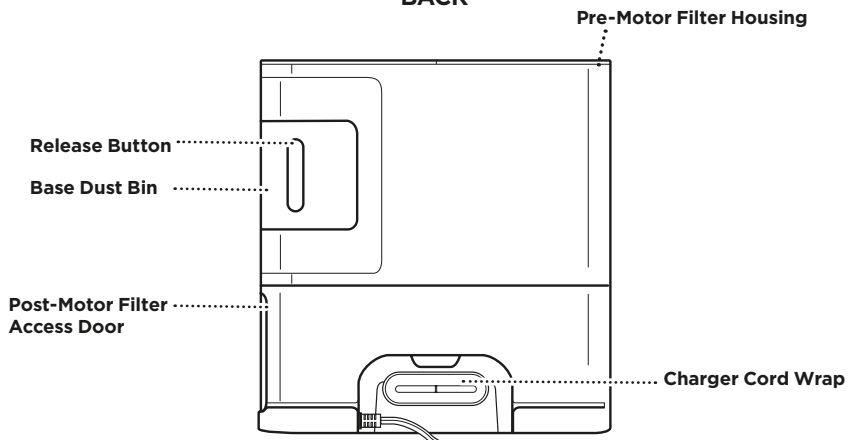

## LIVING WITH YOUR ROBOT

**Questions?** For how-to videos, FAQs, troubleshooting, and tips & tricks, call 1-800-668-9600 for robot support or visit: [support.sharkclean.com](http://support.sharkclean.com)

### DOORWAYS AND THRESHOLDS

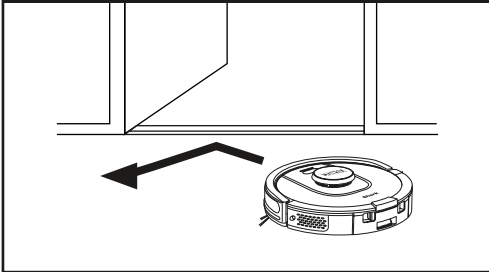

Your robot can easily climb over most thresholds, but if one is higher than 0.75", set up a no-go zone in the app to block it off.

### AVOID MOVING THE ROBOT OR SELF-EMPTY BASE

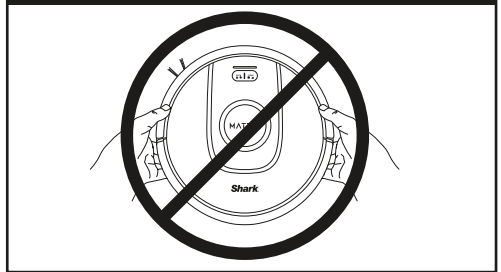

While your robot is cleaning, **DO NOT** pick it up and move it, or move the Self-Empty Base—this will impact the robot's navigation and ability to return to the base when cleaning is complete. If the base is moved, you will need to remap your home.

### CONNECTING YOUR ROBOT



For a connected experience and to access full robot functionality, iOS users must enable Bluetooth and Network Access in the app. Android users must enable Bluetooth, Network Access, and Location Access in the app.

### CAN'T CONNECT TO WI-FI?



#### Restart your phone

- Turn off phone, wait a few minutes, then turn it back on and connect to Wi-Fi.

#### Reboot your robot

- Take robot off base and press and hold down the DOCK button on the robot for 14 seconds. Turn your robot back on by placing it on the base.

#### Reboot your router

- Unplug the router power cable for 30 seconds, then plug it back in. Allow several minutes for your router to reboot completely.
- Then follow the steps outlined in the SharkClean® app Wi-Fi setup instructions.

## PREP YOUR HOME

Your robot uses an array of sensors to navigate around walls, furniture legs, and other obstacles while it cleans. To prevent the robot from entering areas you don't want it to, set up no-go zones in the app. For best results, prepare your home as indicated below, and schedule a daily cleaning to ensure all floor areas are regularly maintained.

**NOTE:** Scheduling is one of many features that can only be done in the app.

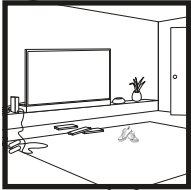

### OBSTRUCTIONS

Clear cords and objects smaller than 4" in height from floors and open interior doors to ensure a complete map of your home.



### SCHEDULING

Schedule whole-home vacuuming runs with the app.

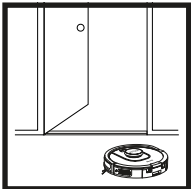

### THRESHOLDS

Your robot can easily climb over most thresholds, but if one is 0.75" or higher, set up a no-go zone in the app to block it off.

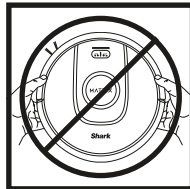

### AVOID MOVING THE ROBOT & SELF-EMPTY BASE

While your robot is cleaning, do not pick it up and move it, or move the base—this will impact the robot's navigation and ability to return to the base when cleaning is complete.

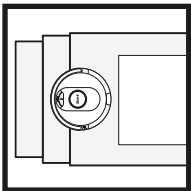

### STAIRS

Your robot's cliff sensors will prevent it from falling off ledges. For the cliff sensors to work properly in any mode, all runners, rugs, or carpets must be at least 8 inches from any stairs, or must extend over the edge of the stairs.

## SELF-EMPTY BASE SETUP

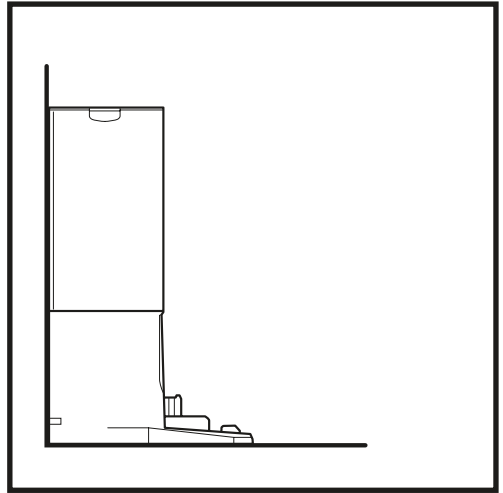
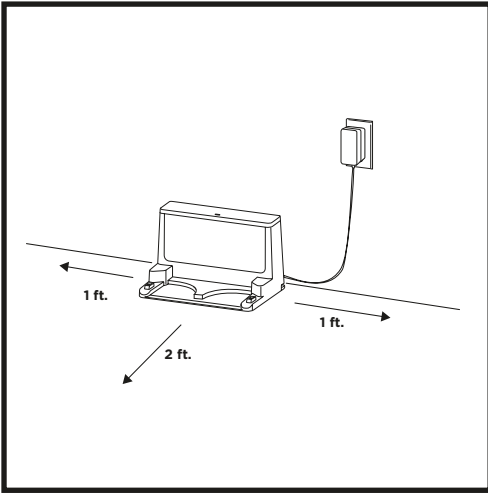

- Place the base with its back against a wall. Select a level surface on a bare floor in a central area with a **strong Wi-Fi signal**. Do not place it against baseboard heaters or other heating elements.
- Select a **permanent** location for the **Self-Empty Base** because every time you relocate it, your robot will have to completely remap your house. Remove protective film from robot and the base.
- **Remove any objects** that are closer than 1 ft. from either side of the base or closer than 2 ft. from the front of the base.
- Plug in the base. The indicator light will **illuminate green when the base has power**.

## INSTALLING THE SIDE BRUSH

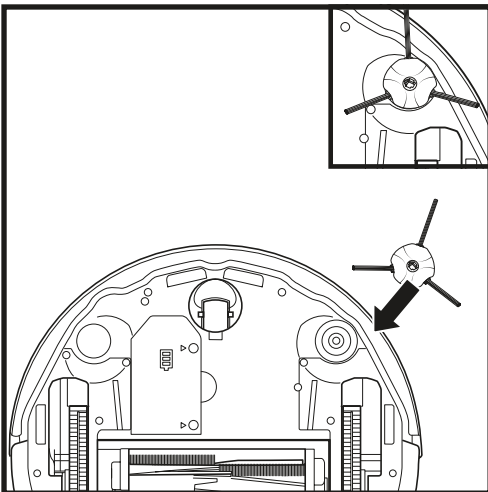

Attach the side brush to the post on the bottom of the robot.

**NOTE:** Side brush design may vary.

## ROBOT INDICATOR LIGHTS

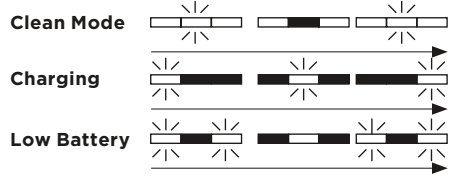
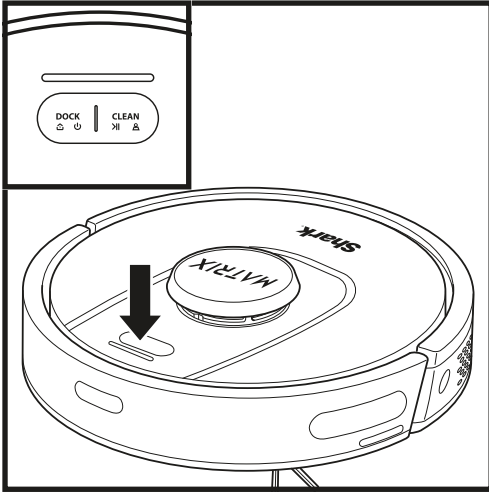

If your robot is low on battery, the left and right indicator lights will flash red. Manually place the robot on the base to begin charging.

While the robot is charging, all three indicator lights will illuminate white successively. It may take up to 6 hours to fully charge your robot.

If the robot is idle and away from the Self-Empty Base for 10 minutes, it will enter **Sleep Mode**. Wake up the robot by pressing any button.

## SELF-EMPTY BASE INDICATOR LIGHTS

- **Base power on and robot charging:** Solid blue
- **Base power on but robot not charging:** Solid green
- **Robot evacuating into Self-Empty Base:** Pulsing green

## CHARGING

**IMPORTANT:** The Shark Matrix™ Plus has a pre-installed rechargeable battery. Charge the battery completely before first use. It may take up to 6 hours to fully charge.

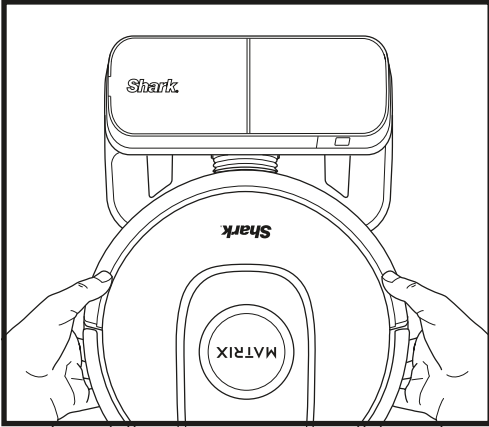

To turn on power, place the robot on the Self-Empty Base. When the robot is correctly placed, the base indicator light will illuminate blue and the robot will beep. If the base indicator light does not turn blue, unplug the cord from the wall outlet, then plug it back in. If the robot has no charge remaining or it can't return to the base, manually place it on the base.

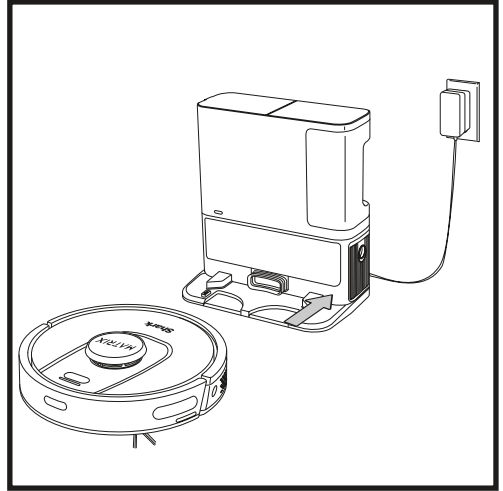

When the cleaning cycle is complete, or if the battery is running low, the robot will search for the Self-Empty Base. If the robot doesn't return to the base, its charge may have run out.

**NOTE:** When manually placing the robot on the Self-Empty Base, make sure the **Charging Contacts** on the bottom of the robot are touching the ones on the base.

**NOTE:** When picking up the robot, be careful not to place fingers between the bumper and the back of the robot.

## DOCK AND CLEAN BUTTONS

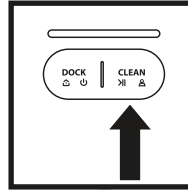
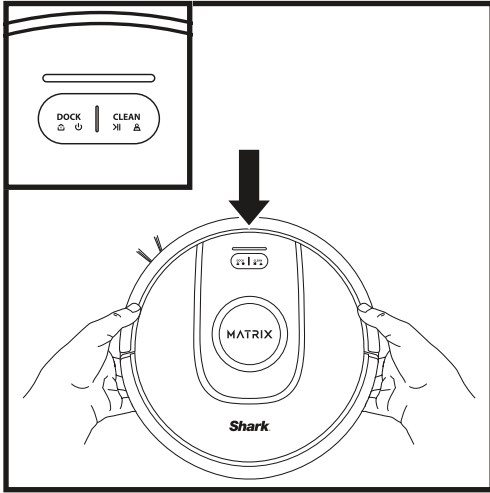

### CLEAN BUTTON

If the robot is on the base, press the CLEAN button for a whole-home clean. Press again to pause the cleaning session.

For a Matrix Spot Clean of a specific 5-foot-by-5-foot area, place the robot in the spot to be cleaned, then press and hold the CLEAN button for 5 to 7 seconds.

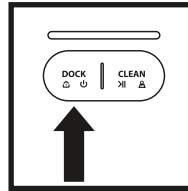

### DOCK BUTTON

To turn on/off your robot, press the DOCK button for 5-7 seconds.

Press the DOCK button to allow the robot to go back to the Self-Empty Base.

To reboot the robot, remove the robot from the base and press and hold the DOCK button for 14 seconds. To turn back on, return the robot to the base.

## CLEANING MODES

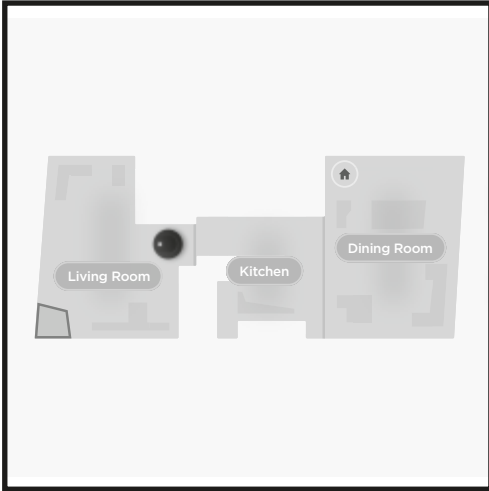

### Whole-Home Cleaning

To activate a whole-home clean when in vacuum-only mode, press the CLEAN button on the robot or in the app. The robot will clean perimeter areas first, then change to a row-by-row pattern.

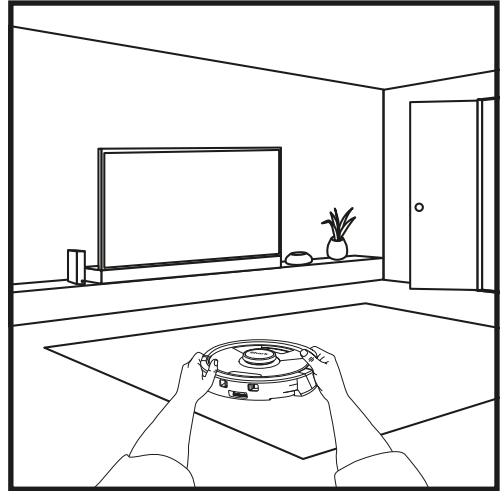

### Single-Room Matrix Clean

Once the robot has a created map, you can select a specific room for it to vacuum in Matrix Clean mode. Place the robot in the room to be cleaned, then press the CLEAN button. This function is also available through the app.

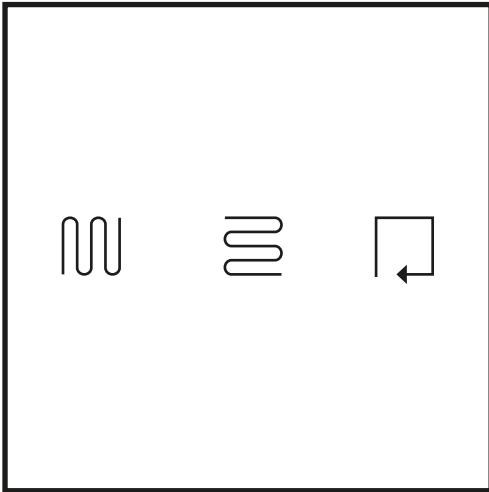

### Spot Clean

To clean a specific 5-foot-by-5-foot spot, place the robot in the area to be cleaned, then press and hold the CLEAN button for 5 to 7 seconds. The robot will clean the area in a matrix pattern. Spot Clean is also available through the app.

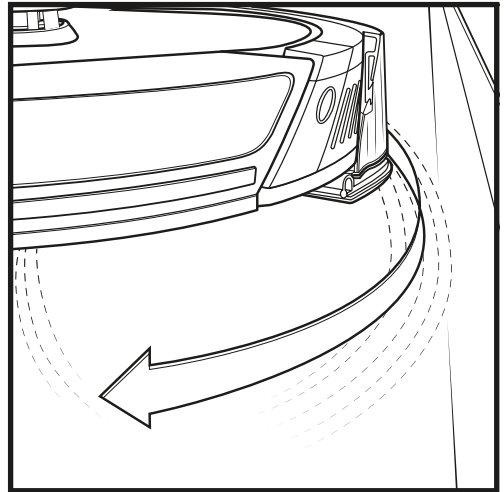

### CleanEdge

In CleanEdge mode, the fanjet blows air into the edges and corners of the room so that the robot can easily pick up debris from hard-to-clean areas. CleanEdge is automatically activated when the robot runs alongside walls at the start of its run, then turns off when the robot cleans the rest of the area.

# USING THE SHARK MATRIX™ PLUS

Please visit [support.sharkclean.com](http://support.sharkclean.com) or call 1-800-668-9600 for answers to all your app questions.

## USING THE SHARKCLEAN® APP AND VOICE CONTROLS

Get the most out of your Shark Matrix™ Plus with these app features:

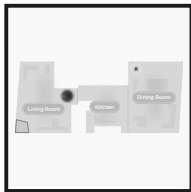

- **Recharge and Resume**  
The robot will return to the Self-Empty Base, recharge, and can pick up where it left off.
- **Matrix Clean:** Targeted precision grid deep cleaning for a specific room or single spot.
- **No-Go Zones**  
Use the no-go zones in the app to keep your robot out of the areas you would like it to avoid.

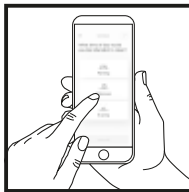

- **Scheduling**  
Set up whole-home cleanings for any time, any day.
- **Control From Anywhere**  
Wherever you are, you're in control of your robot.
- **Cleaning Reports**  
Each time your robot cleans, your app will generate a cleaning report.

Search for **SharkClean** in the app store and download the app to your iPhone™ or Android™.



### SETTING UP VOICE CONTROL WITH THE GOOGLE ASSISTANT OR AMAZON ALEXA

Visit [support.sharkclean.com](http://support.sharkclean.com) for setup instructions, which include how to enable Shark Skill for Amazon Alexa and using with Google Assistant.

#### Google Assistant:

- Hey Google, start vacuuming.
- Hey Google, tell (robot name) to vacuum.
- Hey Google, pause vacuuming.
- Hey Google, tell (robot name) to go home.

#### Amazon Alexa:

- Alexa, ask Shark to start vacuuming/cleaning the (room name).
- Alexa, start/stop the vacuum.
- Alexa, send the vacuum to Self-Empty Base.

### WI-FI TROUBLESHOOTING

- Typical home Wi-Fi networks support 2.5 GHz.
- Do not use a VPN or a proxy server.
- Make sure Wi-Fi isolation is turned off on the router.
- If you cannot connect, call 1-800-668-9600.

### STILL CAN'T CONNECT?

#### Restart your phone

Turn off phone, wait a few minutes, then turn it back on and connect to Wi-Fi.

#### Reboot your robot

- Take robot off Self-Empty Base and press and hold the DOCK button on the robot for 5-7 seconds to turn off power. To turn power back on, place the robot back on the base.

#### Reboot your router

- Unplug the router power cable for 30 seconds, then plug it back in. Allow several minutes for your router to reboot completely.

ERROR CODE	PROBLEM
LEFT LED (BLUE) + MIDDLE LED (RED) flashing + RIGHT LED (BLUE)	Wrong password for Wi-Fi
LEFT LED (BLUE) + MIDDLE LED (RED) flashing + RIGHT LED (BLUE)	SSID cannot be found, try connecting again
LEFT LED (BLUE) + MIDDLE LED (RED) flashing + RIGHT LED (BLUE)	Cannot connect to Wi-Fi

### **How do I use my robot with Amazon Alexa?**

Open the Amazon Alexa app, go to the menu and select Skills. Or go to the Alexa Skills store on the Amazon website. Search for "Shark Skill". Select the Shark Skill to open the detail page, then select the Enable Skill option. Once enabled, you can ask Alexa to control your robot (i.e., "Alexa, tell Shark to start cleaning").

### **How do I set up my robot with the Google Assistant on an Apple device?**

**1.** Download, open, and sign into the Google Assistant app. **2.** Select the "Explore" icon. Search for "Shark" and select "Try it." **3.** To allow Google to link to your SharkClean® account, sign into your SharkClean® account. This is the same account you used when setting up your Shark robot in the SharkClean® app. Select "Authorize" to link your SharkClean® account to the Google Assistant. Congratulations! The Google Assistant now works with your Shark robot. To send your robot into action, use the voice command, "Google, tell Shark to start cleaning."

### **How do I set up my robot with the Google Assistant on Android?**

**1.** Download, open, and sign into the Google Assistant app. **2.** Select the "Explore" icon. Search for "Shark" and select "Link." **3.** Sign into your SharkClean® account. This is the same account you used when setting up your Shark robot in the SharkClean® app. Congratulations! The Google Assistant now works with your Shark robot. To send your robot into action, use the voice command, "Google, tell Shark to start cleaning."

### **What should I do if my Wi-Fi randomly disconnects?**

Turn OFF the robot, by pressing and holding the DOCK button for 5-7 seconds. Wait 10 seconds, then turn the robot power back on by pressing and holding the DOCK button for 5-7 seconds. Turn off your phone. Wait 30 seconds, then turn your phone back on. Open Wi-Fi settings on your phone, find the Shark network, and select Forget Network. Reopen SharkClean® app and retry the connection process. It is normal for your robot to temporarily lose connectivity when it goes under furniture or moves far from your router. Your Shark® robot will automatically reconnect to Wi-Fi. If the robot does not reconnect, power it off, wait 10 seconds, power the robot back on, and place it back on the base.

### **What should I do if I verified a wireless network password that is incorrect?**

Close the app, then reopen it. Make sure that you entered the correct Wi-Fi network password this time. In your phone's network settings, choose your home 2.4 GHz network, and select Forget. Reconnect to your home network. Make sure to use the correct password. If you were able to connect to your home network, proceed to the app setup process. We recommend that you use the eye icon when entering your password to make sure it is correct. Turn off your router and wait 30 seconds. Turn your router back on. Check to make sure your 2.4 GHz network is visible in your phone settings. Turn off the robot, then wait 10 seconds. Turn the robot back on and wait for the voice prompt. Hard-close the app and restart the connection process on the robot. If you cannot locate your Wi-Fi password, please contact your Internet service provider.

### **What should I do if my username or password is invalid?**

We recommend you select the eye icon next to the password entry to verify you are entering your password correctly. Select the 'Forgot Password' option on the sign-in page. The automated system will email you a link to reset your password. If you do not see an email, search your inbox and spam folder for emails from mysharkninja@sharkninja.com. You can use the "Resend code" option to send the email again.

### **What should I do if there is an issue resetting password (did not receive the email or token was invalid)?**

Select the 'Forgot Password' option on the sign-in page. The automated system will email you a link to reset your password. If you do not see an email, search your inbox and spam folder for emails from mysharkninja@sharkninja.com. You can use the "Resend code" option to send the email again.

### What should I do if my Shark® robot won't connect to Wi-Fi or loses Wi-Fi connectivity?

If you are an iOS user and updated to a new version of iOS, you may need to enable local network access on your phone for the SharkClean® app. Please take the following steps to enable. Go to your phone settings --> Select Privacy --> Select Local Network --> Toggle SharkClean on, then try connecting again. Make sure your phone is connected to your home Wi-Fi network before trying to connect your robot. Typical home Wi-Fi networks support both 2.4 GHz and 5 GHz. Make sure you are connected to a 2.4 GHz network when you enter your username and password. Ensure your robot is turned on and you hear an audio prompt. Do not use a VPN or a proxy server. Make sure Wi-Fi isolation is turned off on the router.

There may be instances where your Shark robot loses connectivity while operating, due to a weak Wi-Fi signal, or entering a zone that blocks Wi-Fi.

Turn off the robot. Wait 10 seconds, then turn the power back on and wait for the voice prompt. Power off your phone, wait 30 seconds, and power back on.

Open Wi-Fi settings on your phone, find the Shark network, then select Forget Network. Reopen the SharkClean® app and retry the connection process.

It is normal for your robot to temporarily lose connectivity when it goes under furniture, or moves far from your router. Your Shark robot will automatically reconnect to Wi-Fi. If the robot does not reconnect on its own, remove the unit from the Self-Empty Base. Power the robot off, wait 10 seconds, and place it back on the base.

**NOTE:** Be sure to charge the robot completely before its first cleaning so that it can explore, map, and clean as much of your home as possible. It may take up to 6 hours to fully charge your robot.

## USING THE SHARK MATRIX™ PLUS

### AI LASER NAVIGATION®

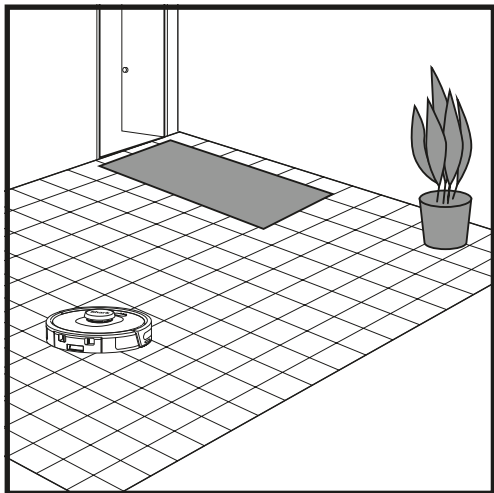

After setup is complete, your robot will conduct an **Explore Run** to create an initial map of your home. The robot will travel from room to room to identify walls, furniture, and other obstacles as it cleans. This run will take less time than a full cleaning, as it doesn't cover the entire floor.

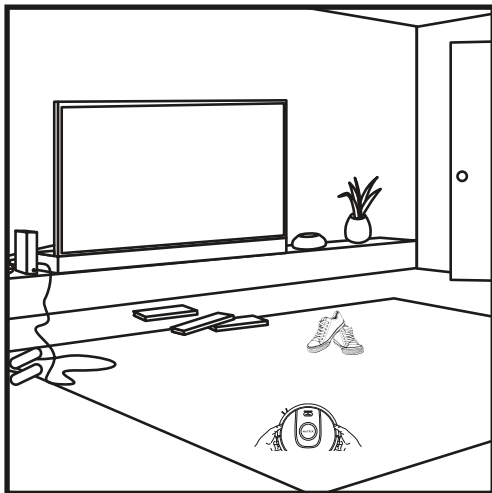

The robot's object detection technology helps it navigate around obstacles taller than 4.5" in height. Create no-go zones in the app to block off areas you do not want the robot to enter. You can set up no-go zones around small objects, or use them to block off large areas.

### MANUAL CLEANING MODE

To manually start a cleaning cycle, press the CLEAN button on the robot or on the mobile app. To immediately send the robot back to the Self-Empty Base, press the DOCK button.

### MATRIX CLEAN

Matrix Clean is targeted deep cleaning of a specific room or spot. A Matrix Clean can be activated with the SharkClean® app, or manually without the app.

To set up a Matrix Clean with the app, select a specific room or spot to be cleaned on the map. Your robot will clean this targeted area on demand.

For a Matrix Spot Clean of a specific 5-foot-by-5-foot area, place the robot in the spot to be cleaned, then press and hold the CLEAN button for 5 to 7 seconds.

**NOTE:** Be sure to charge the robot completely before its first cleaning so that it can explore, map, and clean as much of your home as possible. It may take up to 6 hours to fully charge your robot.

**NOTE:** Avoid moving the Self-Empty Base. If it is relocated, the robot may not be able to find its way back. If the robot is relocated while in use, it may not be able to follow its intelligent cleaning path, or find its way back to the base.

## MAINTENANCE

### MAINTAINING THE BASE DUST BIN

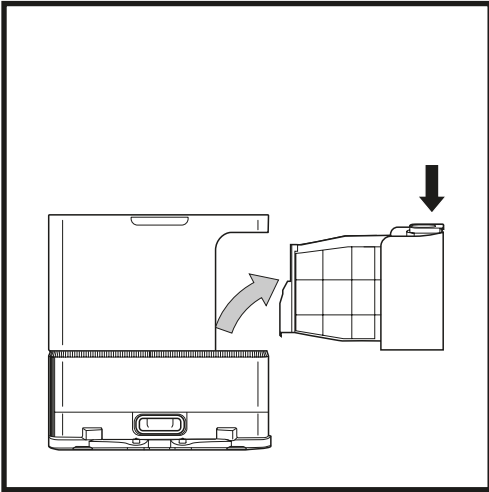

Depending on the size of the base, empty the base dust bin every 30 to 60 days or as needed.

To detach the bin, press the **Dust Bin Release** button on the back right side of the base, then slide out the bin.

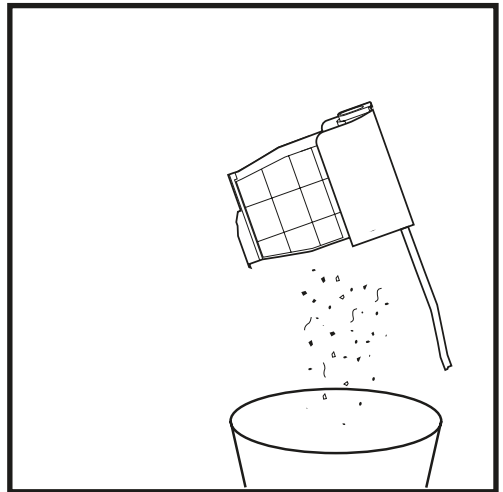

To empty the bin, hold it over the trash, then press the release button with the trash can icon on the side of the bin. The bin lid will open, releasing dust and debris. Lightly tap the dust bin against the inside of the trash receptacle to knock off any remaining debris. Reinstall the bin by sliding it into the slot in the base until it clicks into place.

## MAINTENANCE

### CLEANING AND REPLACING THE BASE FILTERS

Regularly clean the filters to keep your vacuum's suction power optimal. Replace filters every 6-12 months or as needed.

**IMPORTANT: DO NOT** use soap when cleaning the filters.

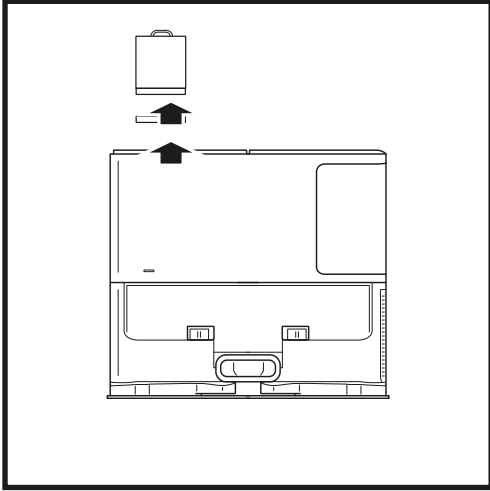

#### CLEAN PRE-MOTOR FILTERS ONCE A MONTH

To open the filter housing lid, hold the top left edge of the base and pull up on the lid. With the lid open, remove the foam filter by the top handle, then lift out the felt filter underneath. Tap the filters clean over the trash, then rinse with cold water **ONLY**, as soap may damage them. Allow filters to air-dry completely before reinstalling them. The filters must be installed correctly for the base to work properly. Reinsert the felt filter first, then the foam filter.

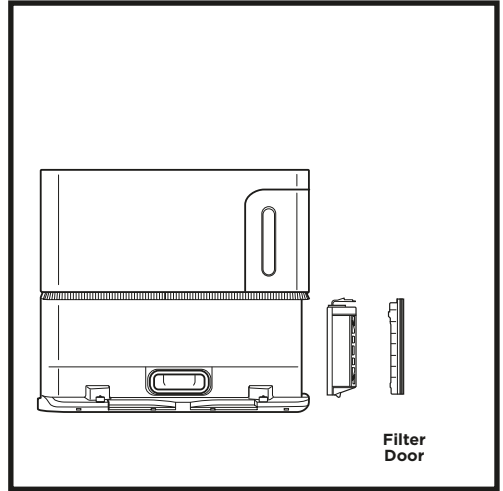

#### CLEAN POST-MOTOR FILTER EVERY YEAR

Press the button at the top of the Filter Door and slide the latch down to lift Filter Door off. Remove the **Post-Motor Filter** from the base by pulling the tab down. Tap the filters clean over the trash. Do not use water or soap to clean filters as this will cause damage. To reinstall the post-motor filter, insert it into the base and replace the filter door.

## MAINTENANCE

**CAUTION:** Turn off power before performing any maintenance. To turn the robot power off, press the DOCK button on the robot for 5-7 seconds.

### EMPTYING THE ROBOT DUST BIN

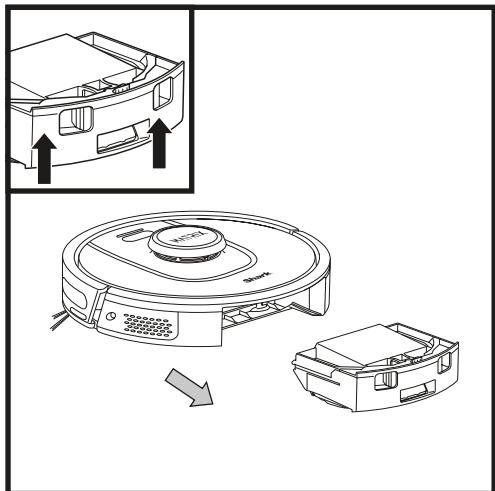

Press the **Dust Bin Release Button** and slide out the dust bin.

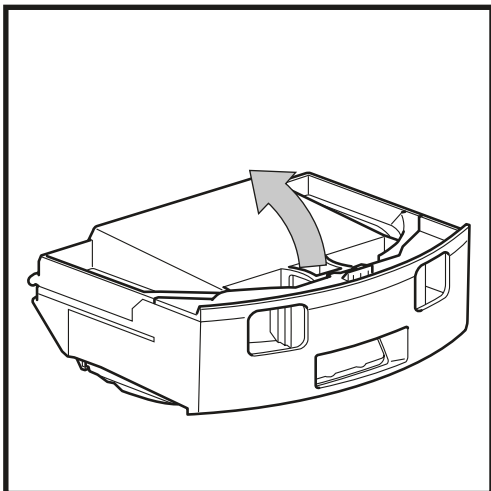

To open the dust bin, press the finger slots and lift the lid.

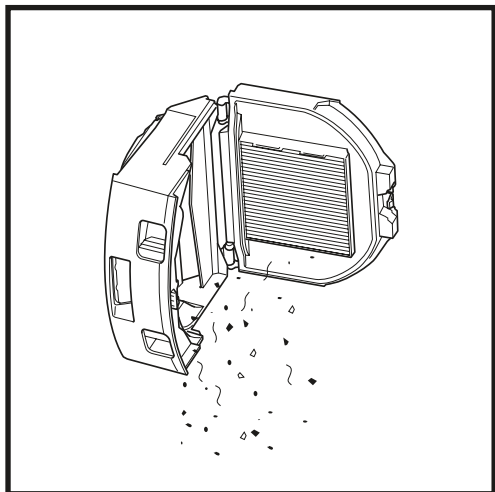

Every time you empty the dust bin, lightly tap dust and dirt off the filter, then use a dry cloth or soft brush to remove any remaining debris.

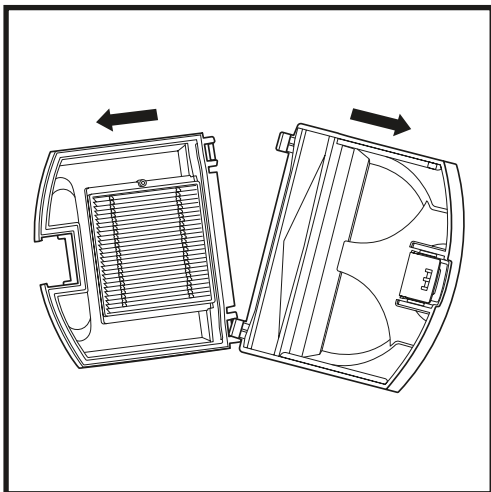

To clean the dust bin lid, snap it off the bin and brush off dust and debris. Do not use water to clean the lid, as this may damage the filter. After cleaning, snap the lid back onto the bin.

**NOTE:** After emptying the dust bin, make sure to reinsert it completely, until it clicks into place.

## MAINTENANCE

### CLEANING THE ROBOT'S FILTER

For optimal suction power, after each use, clean the filter inside the robot's dust bin.

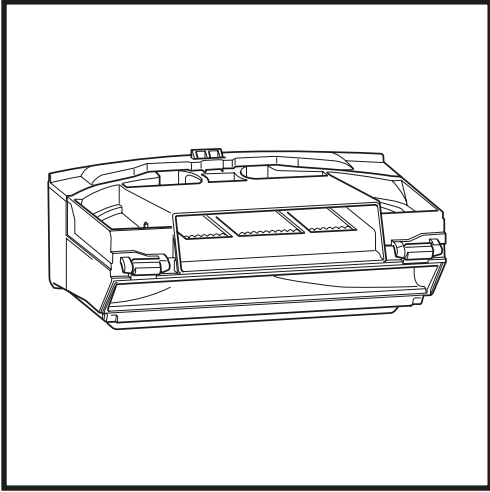

Remove and empty the dust bin. Clean any hair or debris on the back of the dust bin.

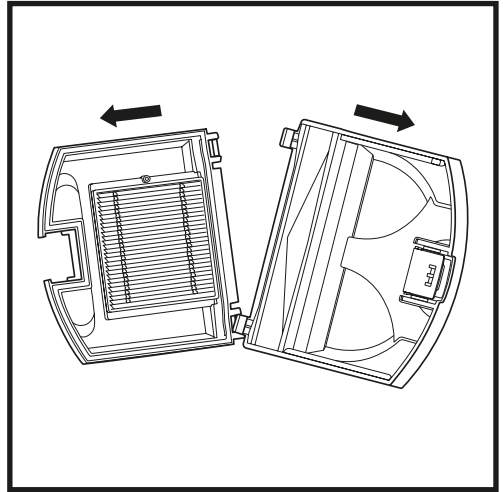

To clean the dust bin lid, snap it off the bin and brush off dust and debris. Do not use water to clean the lid, as this may damage the filter. After cleaning, snap the lid back onto the bin.

## MAINTENANCE

### CLEANING SENSORS AND CHARGING CONTACTS

**CLEAN SENSORS AND CHARGING CONTACTS AS NEEDED.** With a dry cloth, gently dust off the sensors and contacts located on the bottom of the robot and and on the Self-Empty Base.

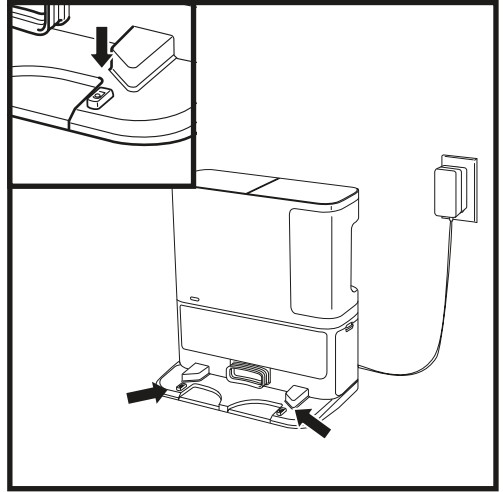
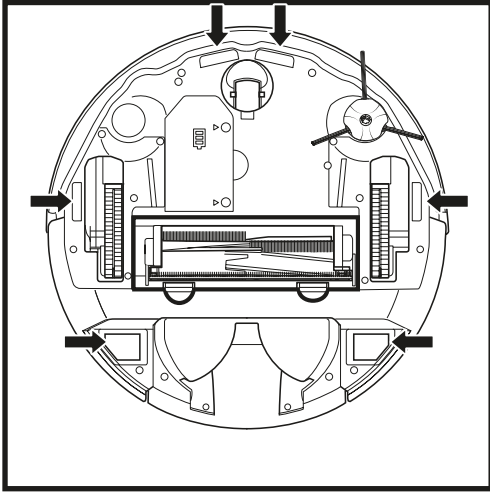

**IMPORTANT:** The robot uses cliff sensors to avoid stairs and other steep drops. Sensors may work less effectively when they are dirty. For best results, clean sensors regularly.

### CLEANING SIDE BRUSH

**CLEAN SIDE BRUSH AS NEEDED.**

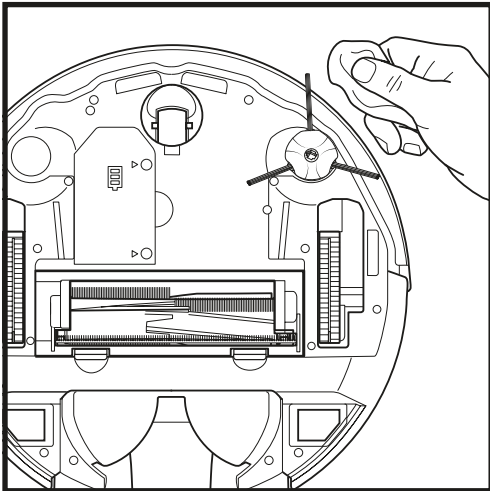

Carefully unwind and remove any string or hair wrapped around brush.

Gently wipe brush with a dry cloth. To reinstall, snap the brush over the peg. Spin the brush manually to make sure it is installed correctly.

**NOTE:** Remove and replace any side brush that is bent or damaged. To remove a brush, lift it off its peg.

## MAINTENANCE

### BRUSHROLL

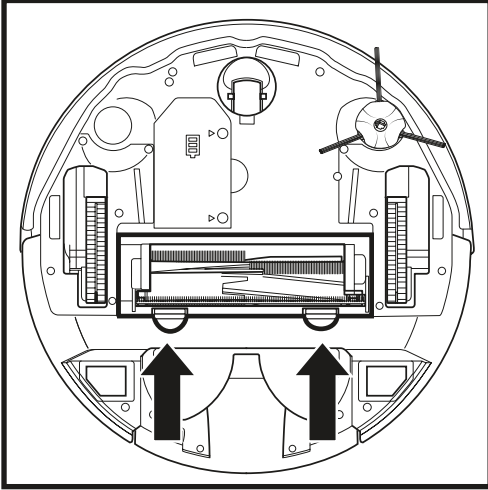

To access the brushroll, push up on the tabs on the brushroll door, then lift off the door.

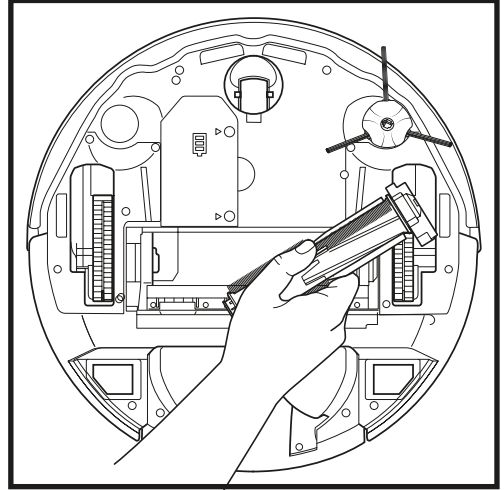

Take out the brushroll and remove the cap on the end. Clean off any hair or debris then replace the cap. Reinstall the brushroll, inserting the flat end first. Close the brushroll access door and press down until both sides click into place.

### LIDAR MODULE

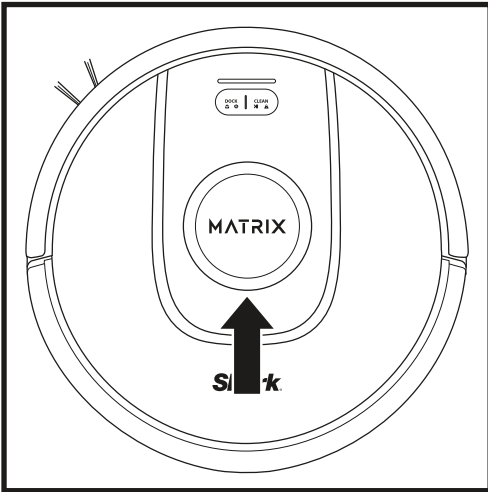

Remove any hair or debris around the navigation module on top of the robot. For a deeper clean, place the robot on a level surface, turn off the power, and spray compressed air into the gap around the LiDAR module to remove any remaining debris.

**NOTE:** Replace brushroll every 6 to 12 months, or when visibly worn. See [sharkaccessories.com](http://sharkaccessories.com) for replacement parts.

## TROUBLESHOOTING

If any error lights are illuminated or flashing on your robot, see the error code chart below:

ERROR CODE	ERROR NUMBER	SOLUTION
<b>MIDDLE LED (WHITE) + RIGHT LED (RED)</b> flashing	<b>2</b>	Side brush is stuck. Remove any debris from around the side brush so it moves freely.
	<b>4</b>	Blockage in brushroll. Remove any debris from around and inside the brushroll so that it can spin freely.
	<b>5</b>	A drive wheel is stuck. Clean the wheels and remove any debris wrapped around the axles so they can move freely.
	<b>18</b>	Wheel motor encoder failure. Please contact Shark Customer Service at 1-800-668-9600.
<b>MIDDLE LED (RED) + RIGHT LED (RED)</b> flashing	<b>3</b>	Suction motor failure. Remove and empty the dust bin, clean the filters, remove the brushroll and brushroll door, and remove blockages.
<b>LEFT LED (RED) flashing + RIGHT LED (WHITE)</b>	<b>6</b>	Front bumper may be jammed. Clean the bumper and make sure it moves in and out freely.
<b>LEFT LED (WHITE) flashing + MIDDLE LED (RED) flashing + RIGHT LED (WHITE)</b>	<b>7</b>	Cliff sensor error. Move your robot to a new location and clean its cliff sensors.
<b>LEFT LED (RED) flashing + MIDDLE LED (RED) flashing + RIGHT LED (WHITE)</b>	<b>9</b>	Robot dust bin needs to be reinstalled. Insert the dust bin until it clicks in place.
<b>MIDDLE LED (RED) flashing + RIGHT LED (WHITE)</b>	<b>10</b>	Robot may be stuck on an obstacle. Move robot to a new location on a level surface.
<b>LEFT LED (WHITE) flashing + MIDDLE LED (RED) flashing</b>	<b>16</b>	Robot is stuck. Move your robot to a new location and make sure the front bumper moves in and out freely.
<b>LEFT LED (RED) flashing + MIDDLE LED (WHITE) flashing</b>	<b>23</b>	Robot cannot find the Self-Empty Base. Please make sure the Self-Empty Base is ON and is free of all obstacles.
<b>LEFT LED (RED) + RIGHT LED (RED) alternating with MIDDLE LED (WHITE)</b>	<b>24</b>	Battery is critically low and needs recharging. Please pick up your robot and place it on the Self-Empty Base. Make sure the Self-Empty Base indicator light turns blue to confirm your robot is placed on the base correctly.
<b>LEFT LED (RED) flashing + RIGHT LED (RED)</b>	<b>26</b>	Blockage in dust bin. Check the Self-Empty Base and the robot dust bin for clogs. Clear any debris and reinstall the dust bin, ensuring that it clicks into place.

For all other issues, please call Customer Service at 1-800-668-9600

## MAINTENANCE

### CLEANING THE WHEELS

#### CLEAN FRONT WHEEL HOUSING PERIODICALLY.

See [sharkaccessories.com](http://sharkaccessories.com) for replacement parts.

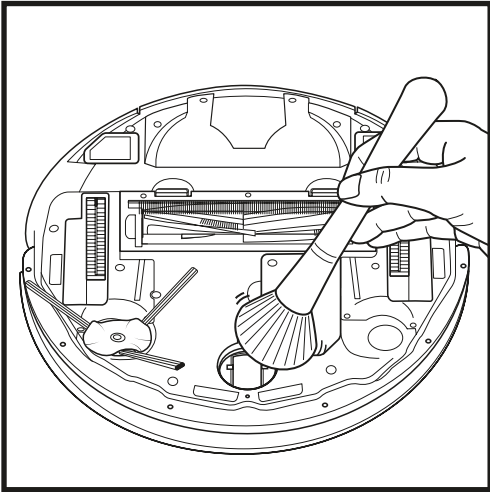

Rotate the front wheel while lightly brushing away dirt and debris. Clean the wheel and the housing around it.

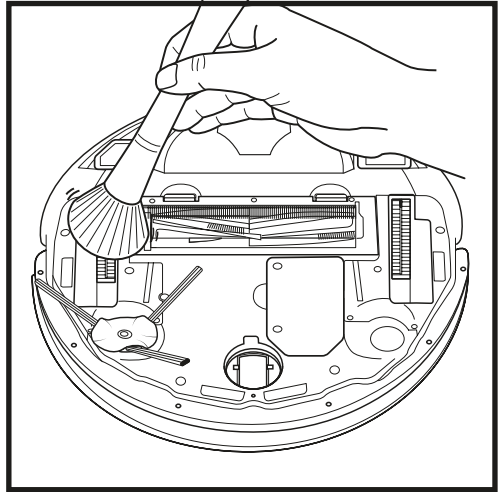

Periodically clean the drive wheels and the housing around them. To clean, rotate each drive wheel while dusting.

**NOTE:** Brush not included.

## REPLACEMENT PARTS

**NOTE:** To order replacement parts visit [sharkaccessories.com](http://sharkaccessories.com).

### REPLACEMENT PARTS: ROBOT

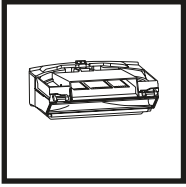

**Robot Dust Bin**

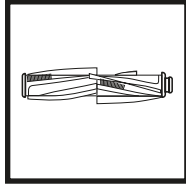

**Brushroll\***

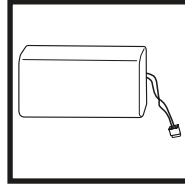

**Battery**

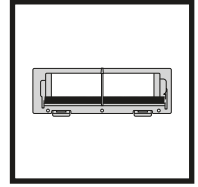

**Brushroll Door\***

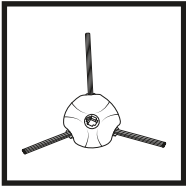

**Side Brush\***

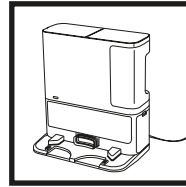

**Self-Empty Base**

**\*NOTE:** Design may vary.

# Questions or Problems?

**CALL US: 1-800-668-9600**

Toll-free customer support line

**GET HELP RIGHT NOW!**  
**DON'T RETURN TO THE STORE.**

**Other easy ways to get help RIGHT NOW:**

## ONLINE HELP AND FAQS:

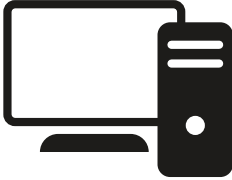

[support.sharkclean.com](https://support.sharkclean.com)

## CONTACT US:



@sharkhome

Contact us on social media

## HOW-TO VIDEOS:



[youtube.com/shark](https://youtube.com/shark)

## APP DOWNLOAD:



Search "**SharkClean**"  
in the app store, or scan  
the QR code with your  
smartphone camera.



**Download and install  
the SharkClean® app**

# END-USER LICENSE AGREEMENT FOR SHARKNINJA SOFTWARE

**IMPORTANT: PLEASE READ THE TERMS AND CONDITIONS OF THIS LICENSE AGREEMENT CAREFULLY BEFORE CONTINUING WITH THIS PROGRAM INSTALL OR USE OF THIS PRODUCT:** SharkNinja Operating LLC's ("SharkNinja") End-User License Agreement ("EULA") is a legal agreement between You (either a single entity or an individual) and SharkNinja for SharkNinja's Software Applications, including those installed by You onto your SharkNinja products or already installed on your device, including all firmware (referred hereafter as "SN APPS"). By installing, copying, checking a box, clicking a button confirming your agreement to these terms, or otherwise continuing to use the SN APPS, You agree to be bound by the terms of this EULA. This license agreement represents the entire agreement concerning SN APPS between You and SharkNinja, and it supersedes any prior proposal, representation, or understanding between the parties. If You do not agree to the terms of this EULA, do not install or use the SN APPS or this product. The SN APPS are protected by copyright laws and international copyright treaties, as well as other intellectual property laws and treaties.

## **1. GRANT OF LICENSE. The SN APPS are licensed as follows:**

- 1.1 Installation and Use. SharkNinja grants You the right to download, install, and use SN APPS on the specified platform for which the SN APP was designed and in connection with SharkNinja products with which the SN APPS are designed to operate ("SN Devices").
- 1.2 Backup Copies. You may also make a copy of SN APPS downloaded and installed by You for backup and archival purposes.

## **2. DESCRIPTION OF OTHER RIGHTS AND LIMITATIONS.**

- 2.1 Maintenance of Copyright Notices. You must not remove or alter any copyright notices on any and all copies of the SN APPS.
- 2.2 Distribution. You may not distribute copies of the SN APPS to third parties.
- 2.3 Prohibition on Reverse Engineering, Decompilation, and Disassembly. You may not reverse engineer, decompile, or disassemble SN APPS, except and only to the extent that such activity is expressly permitted by applicable law notwithstanding this limitation.
- 2.4 Rental. You may not rent, lease, or lend SN APPS without written permission from SharkNinja.
- 2.5 NOT FOR RESALE SOFTWARE. Applications identified as "Not for Resale" or "NFR," may not be resold, transferred, or used for any purpose other than demonstration, test, or evaluation.
- 2.6 Support Services. SharkNinja may provide You with support services related to SN APPS ("Support Services"). Any supplemental software code provided to You as part of the Support Services shall be considered part of SN APPS and subject to the terms and conditions of this EULA.
- 2.7 Compliance with Applicable Laws. You must comply with all applicable laws regarding use of SN APPS.

**3. UPDATES.** SharkNinja may provide You with upgrades or updates to SN APPS. This EULA will govern any upgrades provided by SharkNinja that replace and/or supplement SN APPS, unless such upgrade is accompanied by a separate EULA, in which case the terms of that EULA will govern. If You decide not to download and use an upgrade or update provided by SharkNinja, You understand that You could put SN Apps at risk to serious security threats or cause SN Apps to become unusable or unstable.

**4. DATA AND PRIVACY.** SharkNinja is committed to ensuring your privacy by adhering to high standards of fairness and integrity. We are committed to keeping our customers informed about how we use the information we gather from You through the use of each of our websites or SN APPS. Our privacy practices are described in SharkNinja's Privacy Policy, as well as in separate notices given when an app, product, or service is purchased or downloaded. By using SN APPS or providing us with your personal information, You are accepting and consenting to the practices, terms, and conditions described in SharkNinja's Privacy Policy. At all times your information will be treated in accordance with the SharkNinja Privacy Policy, which is incorporated by reference into this EULA and can be viewed at the following URL:  
<http://www.sharkninja.com/privacypolicy>.

## **5. THIRD-PARTY APPLICATION LIBRARIES AND EMBEDDED SOFTWARE.**

- 5.1 You acknowledge that Amazon Web Services, Inc.. ("AWS") has provided certain application libraries that have been embedded into SN APPS ("AWS Application Libraries") and enables SN Devices to connect to the AWS Cloud Service ("AWS Embedded Software").
- 5.2 You will not use the AWS Application Libraries except as an incorporated portion of SN APPS, unmodified from the form provided to You.
- 5.3 You will not use the AWS Embedded Software except as an incorporated portion of SN Devices, unmodified from the form provided to You.
- 5.4 You will not modify, adapt, translate, or create derivative works based on, or decompile, disassemble, reverse engineer, or otherwise attempt to derive the source code or underlying algorithms of, the AWS Application Libraries or the AWS Embedded Software.
- 5.5 SharkNinja retains all ownership of SN APPS (and the AWS Application Libraries contained therein) and any software installed on SN Devices (including the AWS Embedded Software) and only a license thereto is granted to You for use in connection with the SN APPS and SN Devices.

## END-USER LICENSE AGREEMENT FOR SHARKNINJA SOFTWARE

5.6 You will not use the AWS Application Libraries or AWS Embedded Software to attempt to gain unauthorized access to or use of the systems/services of SharkNinja's other licensors; nor will You transmit viruses, worms, Trojan horses, time bombs, spyware, malware, cancelbots, passive collection mechanisms, rootkits, data mining software, or any other malicious or invasive code or program into the systems/services of SharkNinja's other licensors.

5.7 You will not use the AWS Application Libraries or AWS Embedded Software to interfere with, breach, or circumvent any security feature, authentication feature, or any other feature that restricts or enforces limitations on the use of, or access to, the systems/services of SharkNinja's other licensors.

5.8 You will not probe, attack, scan, or test the vulnerability of the systems/services of SharkNinja's other licensors.

5.9 SharkNinja's other licensors of the SN APPS, AWS Application Libraries, and the AWS Embedded Software are the express third-party beneficiaries of this EULA, and the provisions of this Section of this EULA are made expressly for the benefit of such licensors, and are enforceable by such licensors.

**6. TERMINATION.** Without prejudice to any other rights, SharkNinja may terminate this EULA if You fail to comply with the terms and conditions of this EULA. In such event, You must destroy all copies of SN APPS in your possession.

**7. COPYRIGHT.** All title, including but not limited to copyrights, in and to SN APPS and any copies thereof are owned by SharkNinja or its suppliers. All title and intellectual property rights in and to the content which may be accessed through use of SN APPS are the property of the respective content owner and may be protected by applicable copyright or other intellectual property laws and treaties. This EULA grants You no rights to use such content. All rights not expressly granted are reserved by SharkNinja.

**8. OPEN SOURCE SOFTWARE.** You hereby acknowledge that SN APPS may contain software that is subject to "open source" or "free software" licenses ("Open Source Software"). The license granted by this EULA does not apply to Open Source Software contained in the SN APPS. Rather, the terms and conditions in the applicable Open Source Software license shall apply to the Open Source Software. Nothing in this EULA limits your rights under, or grants You rights that supersede, any Open Source Software license. You acknowledge that the Open Source Software license is solely between You and the applicable licensor of the Open Source Software. To the extent the terms of the licenses applicable to the Open Source Software require SharkNinja to provide the Open Source Software, in either source or executable form, or to provide copies of applicable license terms or other required information, You may obtain a copy of the software by contacting SharkNinja at the below physical address. Additional information about the Open Source Software, and its terms of use, may be found at [www.sharkclean.com/opensource](http://www.sharkclean.com/opensource).

**9. NO WARRANTIES.** SharkNinja expressly disclaims any warranty for SN APPS, AWS Application Libraries, or AWS Embedded Software. SN APPS, AWS Application Libraries, and AWS Embedded Software are provided 'As Is' without any express or implied warranty of any kind, including but not limited to any warranties of merchantability, noninfringement, fitness of a particular purpose, or title. SharkNinja does not warrant or assume responsibility for the accuracy or completeness of any information, text, graphics, links, or other items contained within the SN APPS. SharkNinja makes no warranties respecting any harm that may be caused by the transmission of a computer virus, worm, logic bomb, or other such computer program. SharkNinja further expressly disclaims any warranty or representation to any third party.

**10. LIMITATION OF LIABILITY.** In no event shall SharkNinja or its suppliers be liable for any special, incidental, punitive, indirect, or consequential damages whatsoever (including, but not limited to, damages for loss of profits or confidential or other information, for business interruption, for personal injury, for loss of privacy, for failure to meet any duty including of good faith or of reasonable care, for negligence, and for any other pecuniary or other loss whatsoever) arising out of or in any way related to the use of or inability to use SN Devices or SN APPS, the provision of or failure to provide support or other services, information, software, and related content through the product or otherwise arising out of the use of SN APPS, or otherwise under or in connection with any provision of this EULA, even in the event of the fault, tort (including negligence), strict liability, breach of contract, or breach of warranty of SharkNinja or any supplier, and even if SharkNinja or any supplier has been advised of the possibility of such damages. SharkNinja shall have no liability with respect to the content of the SN APPS or any part thereof, including but not limited to errors or omissions contained therein, libel, infringements of rights of publicity, privacy, trademark rights, business interruption, personal injury, loss of privacy, moral rights, or the disclosure of confidential information.

**11. APPLICABLE LAW.** The laws of the Commonwealth of Massachusetts will govern this EULA and You hereby consent to exclusive jurisdiction and venue in the state and federal courts sitting in the Commonwealth of Massachusetts.

**12. ASSIGNMENT.** SharkNinja may assign this EULA without notice to Licensor.

**13. ENTIRE AGREEMENT.** This EULA (including any addendum or amendment to this EULA which is included with the SN Devices) is the entire agreement between You and SharkNinja relating to the SN APPS and supersedes all prior or contemporaneous oral or written communications, proposals and representations with respect to the SN APPS or any other subject matter covered by this EULA. To the extent the terms of any SharkNinja policies or programs for support services conflict with the terms of this EULA, the terms of this EULA shall control.

If You have questions regarding this EULA, please contact SharkNinja at 89 A Street, Suite 100, Needham, MA 02494.

## TWO (2) YEAR LIMITED WARRANTY

The Two (2) Year Limited Warranty applies to purchases made from authorized retailers of **SharkNinja Operating LLC**. Warranty coverage applies to the original owner and to the original product only and is not transferable.

SharkNinja warrants that the unit shall be free from defects in material and workmanship for a period of two (2) years from the date of purchase when it is used under normal household conditions and maintained according to the requirements outlined in the Owner's Guide, subject to the following conditions and exclusions:

**CALIFORNIA RESIDENTS ONLY:** The one (1) Year Limited Warranty period begins on the original date of delivery or pick-up.

### What is covered by this warranty?

1. The original unit and/or non-wearable components deemed defective, in SharkNinja's sole discretion, will be repaired or replaced with a new or refurbished unit of the same or equivalent model, up to one year from the original purchase date.
2. In the event a replacement unit is issued, the warranty coverage ends six (6) months following the receipt date of the replacement unit or the remainder of the existing warranty, whichever is later. SharkNinja reserves the right to replace the unit with one of equal or greater value.

### What is not covered by this warranty?

1. Normal wear and tear of wearable parts (e.g., not cleaning the filters, not removing debris from the brushroll), which require regular maintenance and/or replacement to ensure the proper functioning of your unit, are not covered by this warranty. Replacement parts are available for purchase at [sharkaccessories.com](http://sharkaccessories.com).
2. Any unit that has been tampered with or used for commercial purposes.
3. Damage caused by misuse (e.g., vacuuming up water or other liquids), abuse, negligent handling, failure to perform required maintenance (e.g., not cleaning the filters, not removing debris from the brushroll), or damage due to mishandling in transit.
4. Consequential and incidental damages.
5. Defects caused by repair persons not authorized by SharkNinja. These defects include damages caused in the process of shipping, altering, or repairing the SharkNinja product (or any of its parts) when the repair is performed by a repair person not authorized by SharkNinja.
6. Products purchased, used, or operated outside North America.

### How to get service

If your appliance fails to operate properly while in use under normal household conditions within the warranty period, visit [support.sharkclean.com](http://support.sharkclean.com)

for product care and maintenance self-help. Our Customer Service Specialists are also available at **1-800-668-9600** to assist with product support and warranty service options, including the possibility of upgrading to our VIP warranty service options for select product categories. Please register your product and have it with you when contacting Customer Service.

SharkNinja will cover the cost for the customer to send in the unit to us for repair or replacement. A fee of \$25.95 (subject to change) will be charged when SharkNinja ships the repaired or replacement unit.

### How to initiate a warranty claim

You must call **1-800-668-9600** to initiate a warranty claim. You will need the receipt as proof of purchase. A Customer Service Specialist will provide you with return and packing instruction information.

### How state law applies

This warranty gives you specific legal rights, and you also may have other rights that vary from state to state. Some states do not permit the exclusion or limitation of incidental or consequential damages, so the above may not apply to you.

## WARRANTY COVERAGE OVERVIEW

### Covered by Warranty

- Manufacturing defects
- Internal hardware or software malfunctions
- Structural failures due to poor workmanship

### Not Covered by Warranty

- Damage from misuse, accidents, or unauthorized repairs
- Normal wear and tear
- Wearable parts (unless defective upon first use)

### Wearable vs. Non-Wearable Parts

Category	Definition
Wearable Parts	Components that naturally degrade over time due to regular use and friction.
Non-Wearable Parts	Core components not expected to degrade under normal use within warranty period.

### Robot Vacuum Parts, Maintenance, and Replacement Guide

Part	Category	Maintenance	Replacement Recommendation	Warranty Coverage
Brushroll	Wearable	Clean weekly	Every 6–12 months	No (unless defective)
Side Brush	Wearable	Clean bi-weekly	Every 3–6 months	No (unless defective)
Filters	Wearable	Clean monthly	Every 2–3 months	No
Dust Bin	Wearable	Empty after each use	As needed	No (unless defective)
Battery	Wearable	Avoid full discharges	Every 12–24 months	Yes (within warranty)
Wheels	Wearable	Check for debris monthly	As needed	No (unless defective)
Charging Dock	Non-Wearable	Keep clean and dry	N/A	Yes
Power Adapter	Non-Wearable	Avoid power surges	N/A	Yes
Pod	Non-Wearable	Wipe clean monthly	N/A	Yes

## REGISTER YOUR PURCHASE



registryourshark.com



## RECORD THIS INFORMATION

Model Number: \_\_\_\_\_

Date of Purchase: \_\_\_\_\_  
(Keep receipt)

Store of Purchase: \_\_\_\_\_

**TIP:** You can find the model and serial numbers on the QR code labels on the bottom of the robot and Self-Empty Base.

## EXPECTED PERFORMANCE

Expected runtime: 60 minutes

Expected charging time: 6 hours

## PLEASE READ CAREFULLY AND KEEP FOR FUTURE REFERENCE.

This Owner's Guide is designed to help you keep your Shark Matrix™ Plus running at peak performance.

SharkNinja Operating LLC

US: Needham, MA 02494

CAN: Ville St-Laurent, QC H4S 1A7

1-800-668-9600

sharkclean.com

Illustrations may differ from actual product. We are constantly striving to improve our products; therefore the specifications contained herein are subject to change without notice.

This product may be covered by one or more U.S. patents. See [sharkninja.com/patents](http://sharkninja.com/patents) for more information.



## FCC WARNINGS

This equipment has been tested and found to comply with the limits for a Class B digital device, pursuant to parts 15 of the FCC Rules. These limits are designed to provide reasonable protection against harmful interference in a residential installation. This equipment generates, uses, and can radiate radio frequency energy and, if not installed and accordance with the instructions, may cause harmful interference to radio communications. However, there is no guarantee that interference will not occur in a particular installation. If this equipment does cause harmful interference to radio or television reception, which can be determined by turning the equipment off and on, the user is encouraged to try to correct the interference by one or more of the following measures:

- Reorient or relocate the receiving antenna.
- Increase the separation between the equipment and receiver.
- Connect the equipment into an outlet on a circuit different from that to which the receiver is connected.
- Consult the dealer or an experienced radio/TV technician for help.

This Device complies with part 15 of the FCC rules. Operation is subject to the following conditions:

1 This device may not cause harmful interference

2 This device must accept any interference received, including interference that may cause undesired operation.

Changes or modifications not expressly approved by the party responsible for compliance could void the user's authority to operate this device.

## ISED STATEMENT

This device complies with Industry Canada license-exempt RSS standard(s). Operation is subject to the following two conditions: (1) this device may not cause interference, and (2) this device must accept any interference, including interference that may cause undesired operation of the device. Le présent appareil est conforme aux CNR d'Industrie Canada applicables aux appareils radio exempts de licence. L'exploitation est autorisée aux deux conditions suivantes : (1) l'appareil ne doit pas produire de brouillage, et (2) l'utilisateur de l'appareil doit accepter tout brouillage radio-électrique subi, même si le brouillage est susceptible d'en compromettre le fonctionnement.



## BATTERY REMOVAL AND DISPOSAL

This product uses a battery. When the battery no longer holds a charge, it should be removed from the vacuum and recycled. **DO NOT** incinerate or compost the battery.

When your lithium-ion battery needs to be replaced, dispose of it or recycle it in accordance with local ordinances or regulations. In some areas, it is illegal to place spent lithium-ion batteries in the trash or in a municipal solid waste stream. Return spent battery to an authorized recycling center or to retailer for recycling. Contact your local recycling center for information on where to drop off the spent battery.

**For more information on battery removal for disposal, please visit [sharkclean.com/batterysupport](http://sharkclean.com/batterysupport).**

The RBRC™ (Rechargeable Battery Recycling Corporation) seal on the lithium-ion battery indicates that the costs to recycle the battery at the end of its useful life have already been paid by SharkNinja. In some areas, it is illegal to place spent lithium-ion batteries in the trash or municipal solid waste stream and the RBRC program provides an environmentally conscious alternative.

RBRC, in cooperation with SharkNinja and other battery users, has established programs in the United States and Canada to facilitate the collection of spent lithium-ion batteries. Help protect our environment and conserve natural resources by returning the spent lithium-ion battery to an authorized SharkNinja service center or to your local retailer for recycling. You may also contact your local recycling center for information on where to drop off the spent battery, or call 1-800-798-7398.

SharkNinja Operating LLC  
US: Needham, MA 02494  
CAN: Ville St-Laurent, QC H4S 1A7  
1-800-668-9600  
[sharkclean.com](http://sharkclean.com)

Illustrations may differ from actual product. We are constantly striving to improve our products; therefore the specifications contained herein are subject to change without notice.

This product may be covered by one or more U.S. patents.

See [sharkninja.com/patents](http://sharkninja.com/patents) for more information.

© 2025 SharkNinja Operating LLC. AI LASER NAVIGATION, SHARK, and SHARKCLEAN are registered trademarks of SharkNinja Operating LLC. SHARK MATRIX is a trademark of SharkNinja Operating LLC. RBRC is a trademark of Rechargeable Battery Recycling Corporation. APPLE, the Apple logo, and iPhone are trademarks of Apple Inc., registered in the U.S. and other countries. APP STORE is a service mark of Apple Inc., registered in the U.S. and other countries. GOOGLE, GOOGLE ASSISTANT, GOOGLE PLAY, the Google Play logo, and Android are trademarks of GOOGLE LLC.

